

**CAST LED Perimeter Wall Pack Light (CPWP1):
 Installation Instructions Wall & Junction Box Mount**

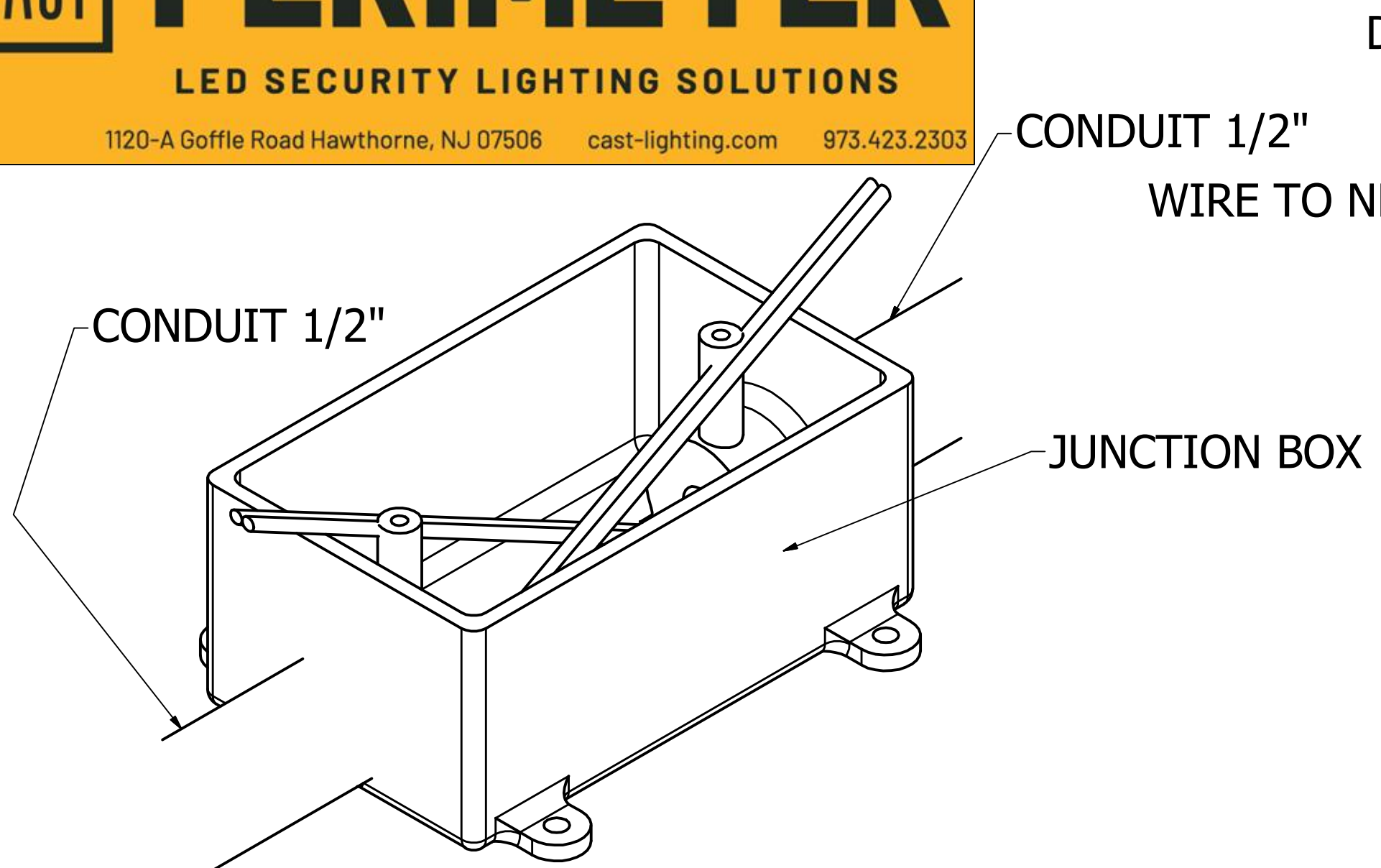

1. HOME RUN WIRE EXIT THE JUNCTION BOX APPROXIMATELY 6" ON BOTH SIDES.

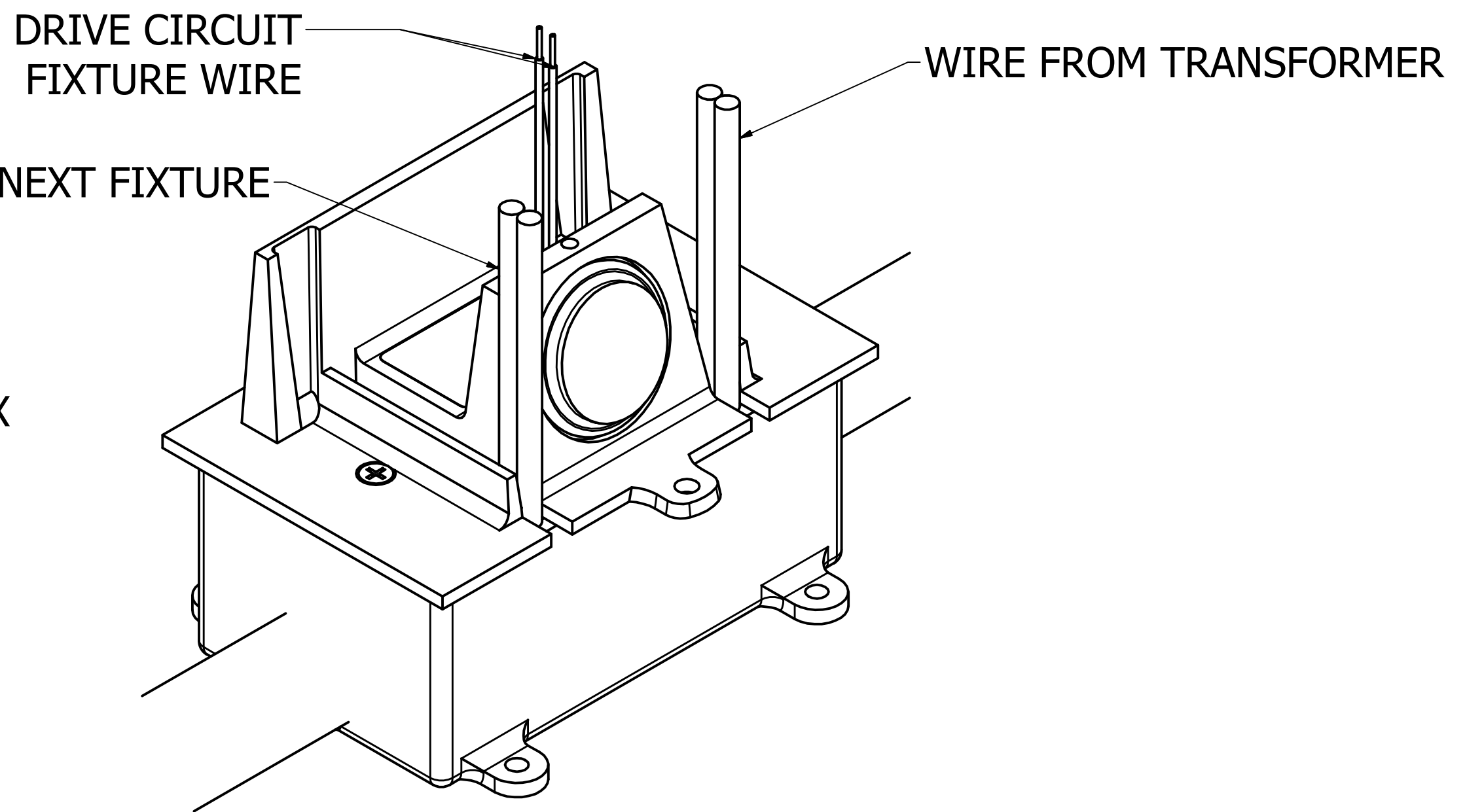

2. STRIP WIRES TO CONNECT TO THE LED MODULE & SECURE MODULE TO JUNCTION BOX (HARDWARE INCLUDED)

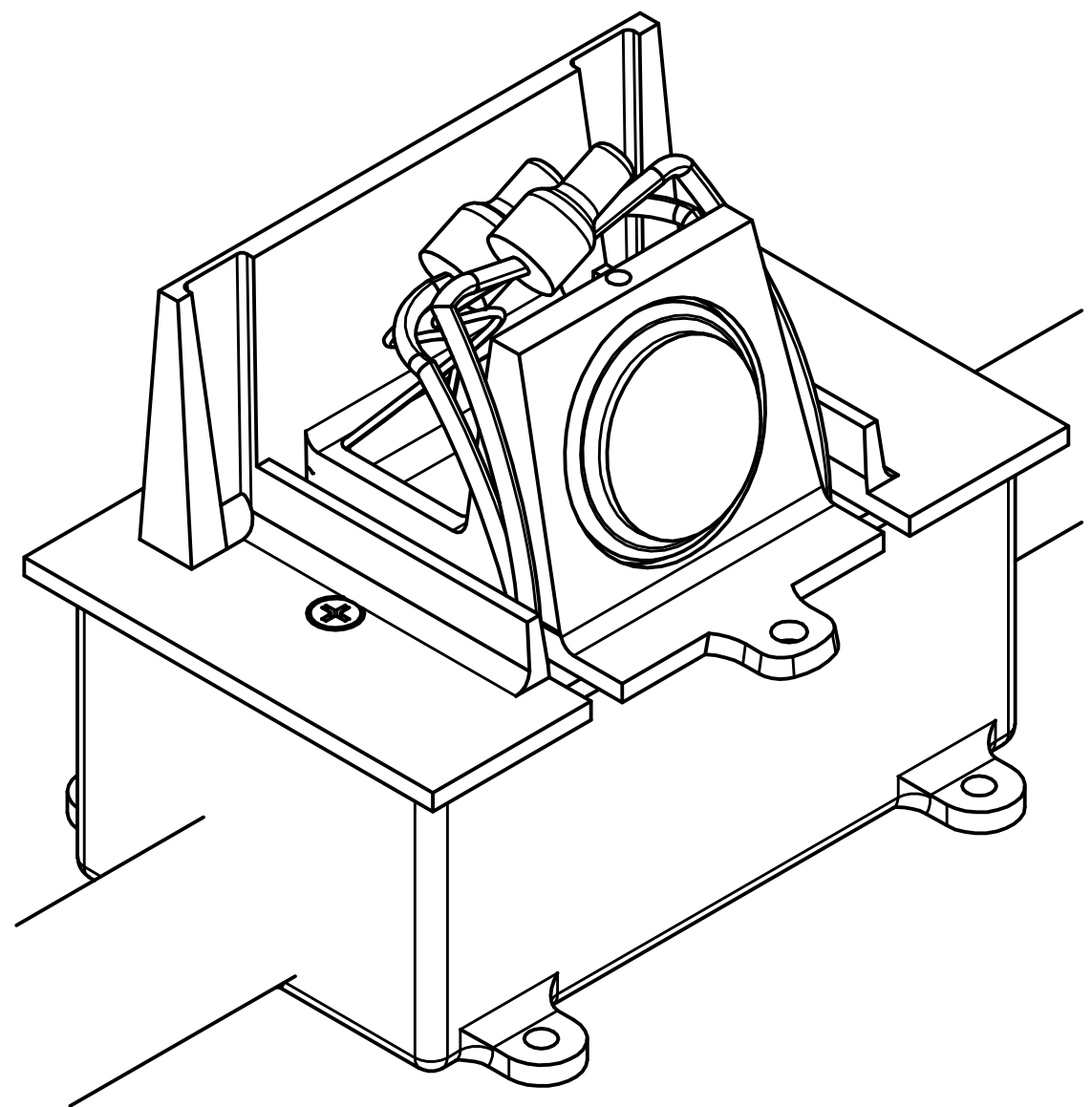
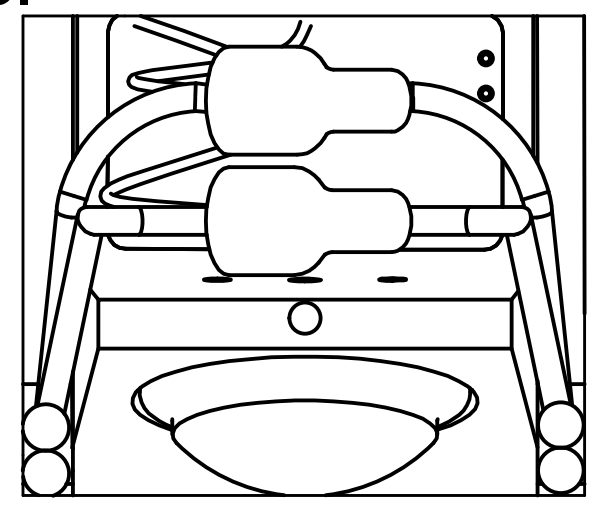

3. MAKE CRIMP CONNECTIONS USING THE WIRE CONNECTORS SUPPLIED WITH EACH FIXTURE. PUSH WIRE CONNECTORS INTO CAVITY WHEN CONNECTIONS ARE COMPLETE.

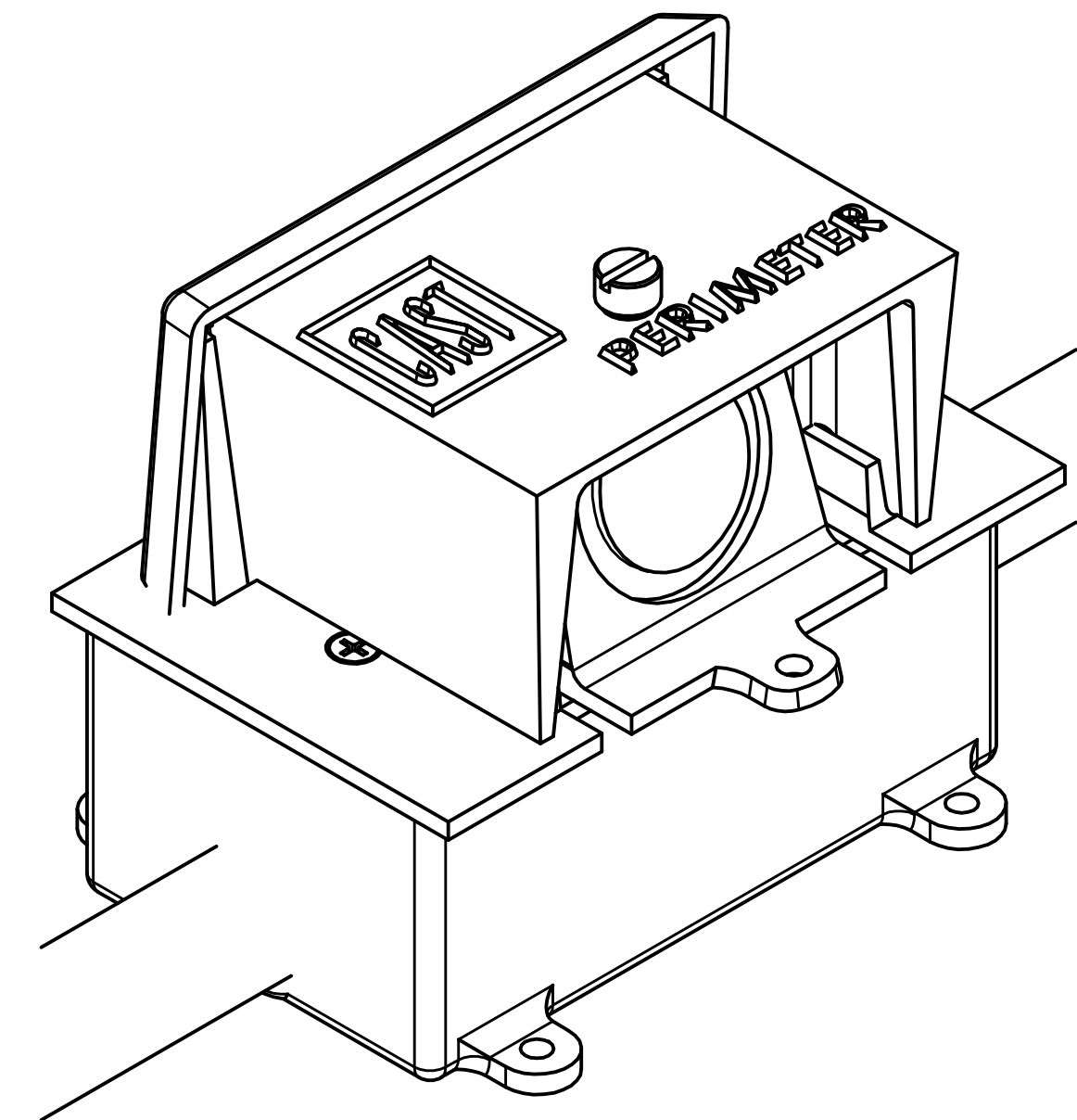

4. ONCE CONNECTIONS ARE COMPLETED ASSEMBLE FRONT COVER & SECURE IN PLACE WITH THUMB SCREW.

**CAST LED Perimeter Wall Pack Light (CPWP1):
 Installation Instructions Wall & Junction Box Mount**

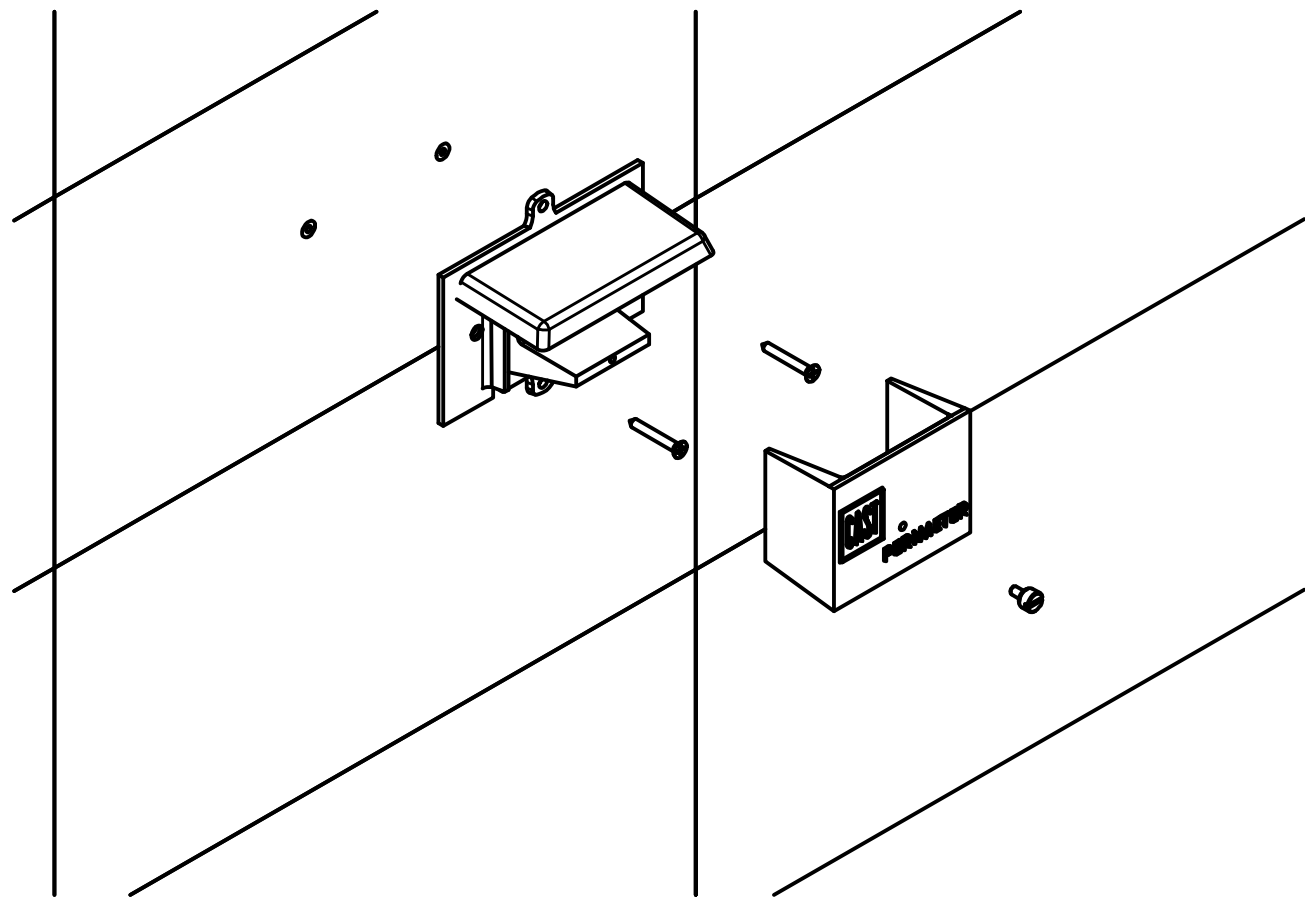

OPTION 1: WALL MOUNT

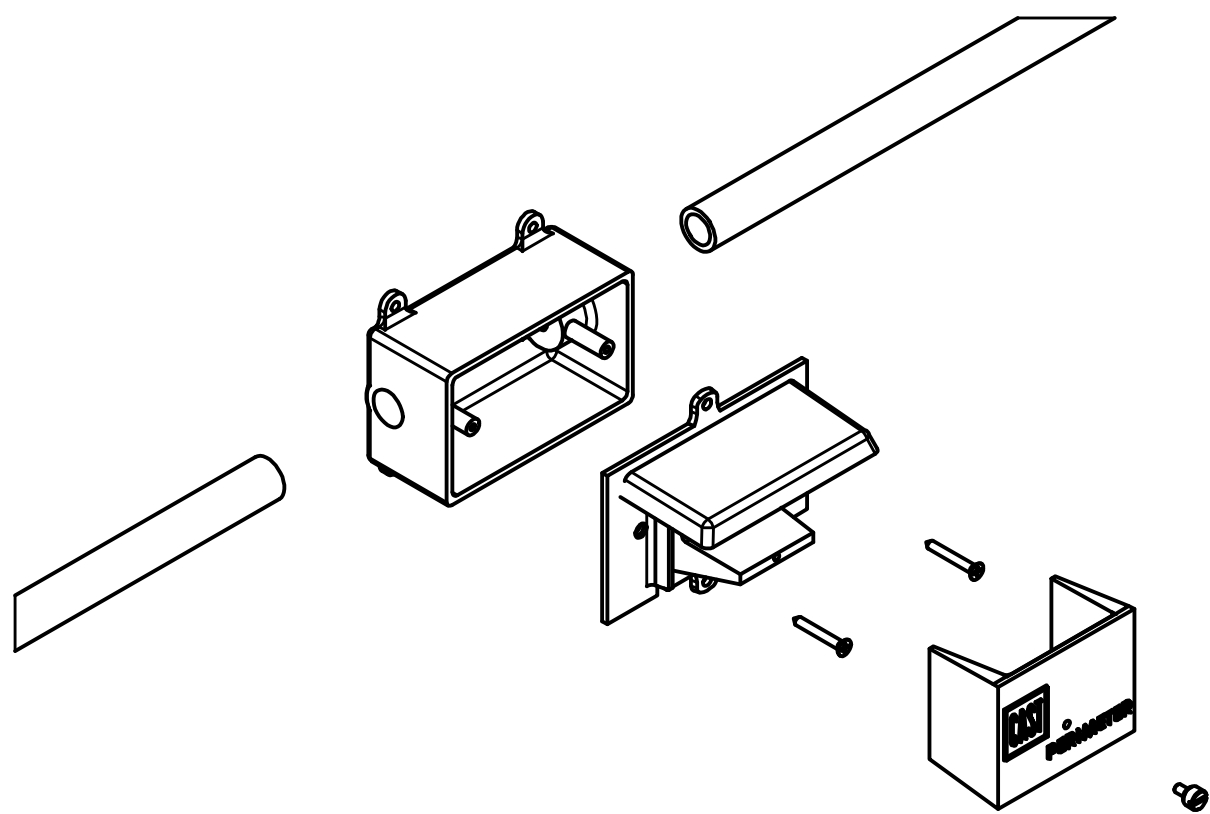

OPTION 2: JUNCTION BOX MOUNT

**ATTACH FIXTURE TO CONCRETE WALL OR JUNCTION BOX
 USING THE HARDWARE (PROVIDED)**

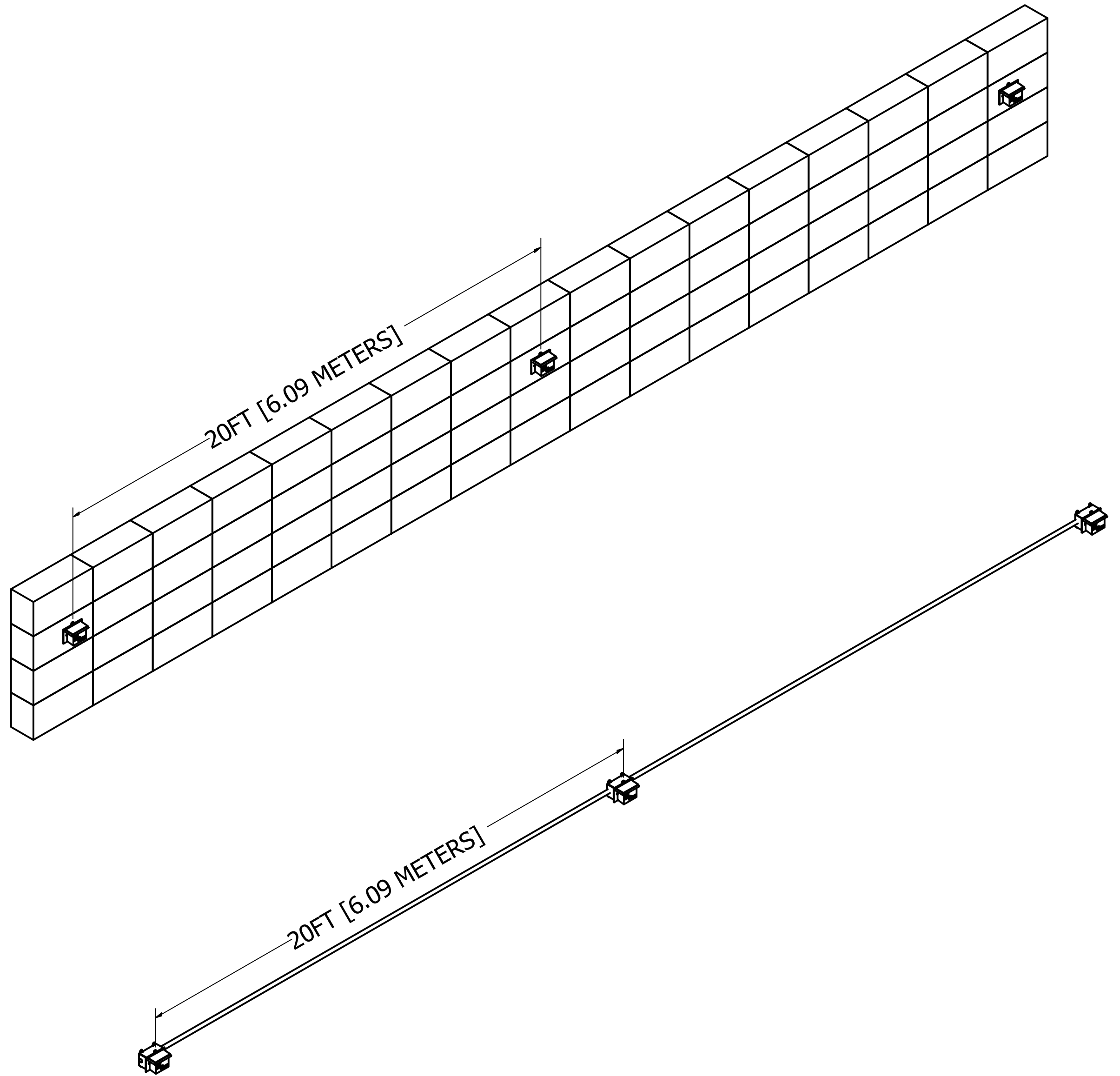

**FIXTURES ARE TYPICALLY INSTALLED AT
 20FT (6.09 METERS) APART**